

*Basic Skills*  
*Test*  
*Mathematics*

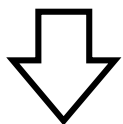

1. ADD: 
$$\begin{array}{r} 5 \\ +7 \\ \hline \end{array}$$

- A. 11
- B. 12
- C. 13
- D. 14
- E. ?

1

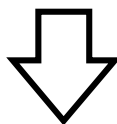

4. SUBTRACT:  $13 - 6 =$

- A. 3
- B. 5
- C. 7
- D. 19
- E. ?

2. ADD:  $6 + 9 =$

- A. 1
- B. 13
- C. 14
- D. 15
- E. ?

5. SUBTRACT:  $16 - 7 =$

- A. 0
- B. 1
- C. 8
- D. 9
- E. ?

3. SUBTRACT: 
$$\begin{array}{r} 17 \\ -9 \\ \hline \end{array}$$

- A. 8
- B. 6
- C. 3
- D. 2
- E. ?

6. ADD: 
$$\begin{array}{r} 346 \\ 173 \\ +287 \\ \hline \end{array}$$

- A. 942
- B. 806
- C. 736
- D. 674
- E. ?

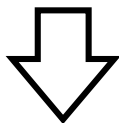

7. ADD:      \$ 24.37  
                  47.23  
                  + 68.60  
                            

- A. \$ 140.20
- B. \$ 140.10
- C. \$ 139.10
- D. \$ 138.20
- E. ?

2

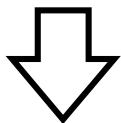

10. SUBTRACT:    \$ 334.20  
  - 156.78  
  

- A. \$ 288.52
- B. \$ 222.58
- C. \$ 187.48
- D. \$ 177.42
- E. ?

8. SUBTRACT:    68,245  
                                  - 42,376  
  

- A. 20,979
- B. 20,131
- C. 19,869
- D. 9,971
- E. ?

11. MULITIPLY:    8  
                                  x 7  
  

- A. 63
- B. 56
- C. 54
- D. 42
- E. ?

9. SUBTRACT:    70,000  
                                  - 69,856  
  

- A. 19,856
- B. 9,856
- C. 144
- D. 44
- E. ?

12. MULITIPLY: 9 x 6 =

- A. 3
- B. 15
- C. 48
- D. 54
- E. ?

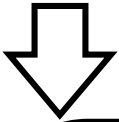

3

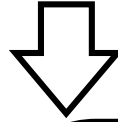
13. DIVIDE:  $7 \overline{)63}$ 

- A. 9
- B. 8
- C. 7
- D. 6
- E. ?

16. MULTIPLY:  $\begin{array}{r} 62 \\ \times 68 \\ \hline \end{array}$ 

- A. 4,216
- B. 4,106
- C. 496
- D. 376
- E. ?

14. DIVIDE:  $\frac{56}{8} = \square$ 

- A. 8
- B. 7
- C. 6
- D. 2
- E. ?

17. MULTIPLY:  $\begin{array}{r} 639 \\ \times 847 \\ \hline \end{array}$ 

- A. 511,133
- B. 532,133
- C. 541,233
- D. 564,233
- E. ?

15. DIVIDE:  $42 \div 6 = \square$ 

- A. 4
- B. 5
- C. 6
- D. 7
- E. ?

18. DIVIDE:  $4 \overline{)379}$ 

- A. 94 r3
- B. 79 r3
- C. 49 r3
- D. 49 r2
- E. ?

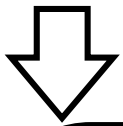

19. DIVIDE:  $44 \overline{)1584}$

- A. 41
- B. 36
- C. 31
- D. 26
- E. ?

4

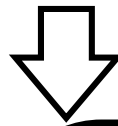

22. Choose another name for  $\frac{7}{8}$

- A.  $\frac{7}{16}$
- B.  $\frac{7}{15}$
- C.  $\frac{21}{24}$
- D.  $\frac{14}{8}$
- E. ?

20. DIVIDE:  $83 \overline{)5059}$

- A. 6 r69
- B. 59 r32
- C. 60 r79
- D. 73
- E. ?

23. Rename  $\frac{18}{30}$  to simplest form  
(lowest terms)

- A.  $\frac{1}{5}$
- B.  $\frac{3}{10}$
- C.  $\frac{1}{3}$
- D.  $\frac{3}{5}$
- E. ?

21. Name the shaded part of the figure.

- A.  $\frac{5}{12}$
- B.  $\frac{7}{12}$
- C.  $\frac{5}{7}$
- D.  $\frac{5}{6}$
- E. ?

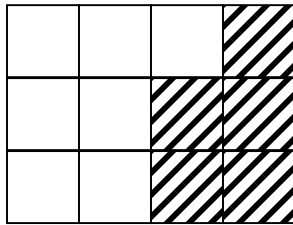

24. Choose a common denominator for  $\frac{6}{7}$  and  $\frac{2}{3}$

- A. 22
- B. 21
- C. 10
- D. 7
- E. ?

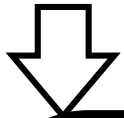

25. Choose another name for  $\frac{43}{6}$ .

- A. 37
- B.  $7\frac{1}{6}$
- C.  $7\frac{6}{43}$
- D.  $7\frac{7}{43}$
- E. ?

5



28. SUBTRACT: (Rename in simplest form)

- A.  $10\frac{9}{11}$        $5\frac{8}{9}$
- B.  $\frac{7}{7}$                $-5\frac{1}{2}$
- C.  $\frac{11}{18}$               \_\_\_\_\_
- D.  $\frac{7}{18}$
- E. ?

26. ADD: (Rename in simplest form)

- A. 6               $3\frac{2}{5}$
- B.  $5\frac{13}{15}$          $+2\frac{1}{3}$
- C.  $5\frac{11}{15}$             \_\_\_\_\_
- D.  $5\frac{3}{8}$
- E. ?

29. ADD: (Rename in simplest form)

- A.  $12\frac{3}{4}$              $6\frac{3}{4}$
- B.  $12\frac{1}{2}$              $+5\frac{3}{4}$
- C.  $12\frac{1}{8}$             \_\_\_\_\_
- D.  $11\frac{3}{4}$
- E. ?

27. SUBTRACT: (Rename in simplest form)

- A.  $\frac{5}{24}$
- B.  $\frac{5}{11}$                $\frac{7}{8}$
- C.  $\frac{5}{5}$                $-\frac{2}{3}$
- D.  $\frac{37}{24}$
- E. ?

30. SUBTRACT: (Rename in simplest form)

- A.  $53\frac{7}{8}$
- B.  $53\frac{3}{8}$              $35\frac{1}{4}$
- C.  $17\frac{3}{8}$              $-18\frac{5}{8}$
- D.  $16\frac{5}{8}$
- E. ?

31. MULTIPLY: (Rename in simplest form)

A.  $1\frac{3}{5}$        $\frac{2}{5} \times \frac{1}{4} = \square$

B.  $\frac{2}{9}$

C.  $\frac{3}{20}$

D.  $\frac{1}{10}$

E. ?

34. DIVIDE: (Rename in simplest form)

A.  $\frac{8}{57}$        $2\frac{3}{8} \div \frac{1}{3} = \square$

B.  $1\frac{5}{24}$

C.  $7\frac{1}{8}$

D. 57

E. ?

32. MULTIPLY: (Rename in simplest form)

A.  $12\frac{4}{5}$        $4\frac{2}{3} \times 2\frac{2}{5} = \square$

B.  $11\frac{1}{5}$

C.  $10\frac{13}{15}$

D.  $8\frac{4}{15}$

E. ?

35. DIVIDE: (Rename in simplest form)

A.  $\frac{2}{27}$        $4\frac{2}{3} \div 7 = \square$

B.  $\frac{2}{3}$

C.  $1\frac{1}{2}$

D.  $32\frac{2}{3}$

E. ?

33. DIVIDE: (Rename in simplest form)

A.  $\frac{40}{54}$        $\frac{8}{9} \div \frac{5}{6} = \square$

B.  $\frac{13}{15}$

C.  $\frac{15}{16}$

D.  $1\frac{1}{15}$

E. ?

36. ADD:  $.07 + 23.6 + 18.02 = \square$

A. 20.45

B. 30.69

C. 31.69

D. 41.69

E. ?

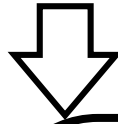
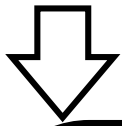

37. SUBTRACT:  $32.56 - 4.2 =$

- A. 9.44
- B. 28.36
- C. 32.14
- D. 32.36
- E. ?

40. Find the correct answer.

23% of 346 =

- A. .7958
- B. 7.958
- C. 79.58
- D. 795.8
- E. ?

38. MULTIPLY: 
$$\begin{array}{r} 41.5 \\ \times .31 \\ \hline \end{array}$$

- A. 12.865
- B. 128.65
- C. 1286.5
- D. 12865.0
- E. ?

41. Find the perimeter.

- A. 16 sq in
- B. 32 in
- C. 32 sq in
- D. 63 in
- E. ?

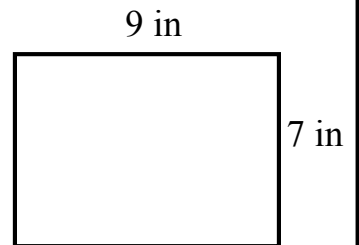

39. DIVIDE:  $.06 \overline{)264}$

- A. .044
- B. .44
- C. 4.4
- D. 44
- E. ?

42. Find the area.

- A. 15 sq in
- B. 18 sq in
- C. 30 sq in
- D. 36 sq in
- E. ?

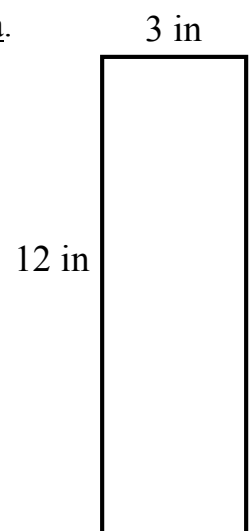



43. Choose the correct answer.

$$81 \text{ in} = \underline{\hspace{1cm}} \text{ yd } \underline{\hspace{1cm}} \text{ in}$$

- A. 2 yd 9 in
- B. 4 yd 1 in
- C. 6 yd 9 in
- D. 8 yd 1 in
- E. ?

44. Choose the correct answer.

$$50 \text{ oz} = \underline{\hspace{1cm}} \text{ lb } \underline{\hspace{1cm}} \text{ oz}$$

- A. 10 lb 0oz
- B. 6 lb 2 oz
- C. 3 lb 2 oz
- D. 1 lb 18 oz
- E. ?

45. Choose the correct answer.

$$27 \text{ qt} = \underline{\hspace{1cm}} \text{ gal } \underline{\hspace{1cm}} \text{ qt}$$

- A. 6 gal 3 qt
- B. 9 gal 0 qt
- C. 10 gal 7 qt
- D. 12 gal 1 qt
- E. ?

46. Choose the most suitable operation to solve this problem.

Carol makes \$4.16 each hour. Last week she worked 40 hours.  
How much money did she make?

- A. Addition
- B. Division
- C. Multiplication
- D. Subtraction
- E. ?

47. Choose the correct answer.

The students in the second period Physical Education class were separated into teams of 7 students each. Eight teams were formed. How many students were in the second period class?

- A. 56
- B. 63
- C. 78
- D. 87
- E. ?

48. Choose the correct answer.

The drill team at Ed Von Tobel Jr. High School went on a field trip. There were 62 boys and 43 girls. If the same number of students went on each bus and there were 5 buses used, how many students went on each bus?

- A. 105
- B. 25
- C. 23
- D. 21
- E. ?

49. Choose the correct answer.

Tyrone had \$1,500.00 in the bank. He bought a new hang glider for \$1,195.00 and a new helmet for \$75.00. How much money did he have left?

- A. \$75.00
- B. \$230.00
- C. \$1,270.00
- D. \$1,425.00
- E. ?

50. Use the circle graph below to answer the following problem.

What percent of the vehicles were full-size cars, trucks and pickups?

- A. 50%
- B. 40%
- C. 30%
- D. 25%
- E. ?

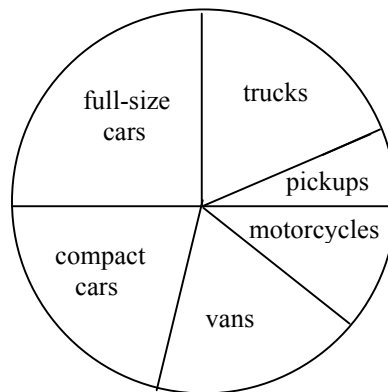

Vehicles Passing Station

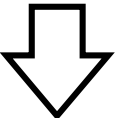

51. Choose the prime factorization of 98.

- A.  $7^2 + 2^1$
- B.  $2^2 \times 7^1$
- C.  $2^1 \times 7^2$
- D.  $9^1 \times 8^1$
- E. ?



54. Round .3068 to the nearest hundredth.

- A. .316
- B. .31
- C. .307
- D. .30
- E. ?

52. Choose another name for  $\frac{2}{5}$

- A. .15
- B. .2
- C. .25
- D. .4
- E. ?

55. Find the reciprocal of  $3\frac{1}{5}$ .

- A.  $\frac{5}{16}$
- B.  $\frac{16}{5}$
- C.  $3\frac{5}{1}$
- D.  $5\frac{1}{3}$
- E. ?

53. Change  $\frac{4}{9}$  to a decimal fraction.

- A. .44
- B.  $.44\frac{4}{9}$
- C. .45
- D. .49
- E. ?

56. ADD:  $25 + 8.9 + 6.73 + .004 =$

- A. 79.1
- B. 44.63
- C. 40.634
- D. 15.884
- E. ?

57. SUBTRACT:  $7\frac{5}{8} - 6\frac{2}{3} = \square$

- A.  $\frac{23}{24}$   
 B.  $1\frac{1}{24}$   
 C.  $1\frac{3}{5}$   
 D.  $13\frac{1}{13}$   
 E. ?



60. SOLVE: 65% of 180 =  $\square$

- A. 117  
 B. 125  
 C. 245  
 D.  $276\frac{12}{13}$   
 E. ?

58. MULTIPLY:  $3\frac{3}{5} \times 2\frac{2}{9} = \square$

- A.  $1\frac{31}{50}$   
 B.  $4\frac{2}{45}$   
 C.  $6\frac{2}{15}$   
 D. 8  
 E. ?

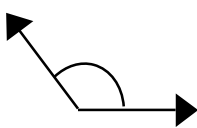
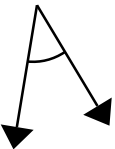
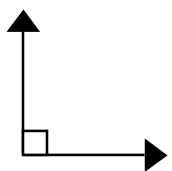
61. Choose the acute angle.

- A. 
- B. 
- C. 
- D. 
- E. ?

59. SOLVE:  $\frac{4.263}{2.1} = \square$

- A. .203  
 B. .230  
 C. 2.03  
 D. 2.30  
 E. ?

62. Two lines that are perpendicular intersect to form:

- A. acute angles  
 B. complementary angles  
 C. obtuse angles  
 D. right angles  
 E. ?

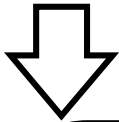

63. Find the measure of  $\angle R$ .

- A.  $35^\circ$
- B.  $55^\circ$
- C.  $90^\circ$
- D.  $145^\circ$
- E. ?

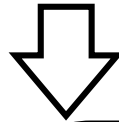
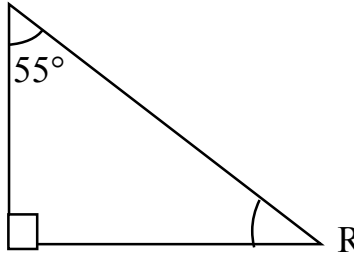

66. SOLVE: 1 meter =

- A. 100 millimeters
- B. 100 centimeters
- C. 100 decimeters
- D. 100 kilometers
- E. ?

64. Choose the equilateral triangle.

- A.
- B.
- C.
- D.
- E. ?

67. SOLVE: 12 grams =

- A. .012 kg
- B. 12 dg
- C. 12.0 cg
- D. 120 mg
- E. ?

65. Choose the radius of circle W.

- A.  $\overline{UV}$
- B.  $\overline{VY}$
- C.  $\overline{XZ}$
- D.  $\overline{VW}$
- E. ?

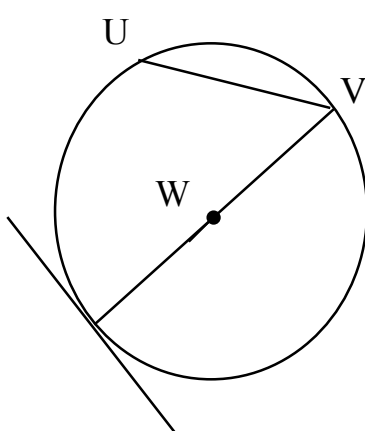

68. Find the perimeter of rectangle EFGH.

- A. 65 m
- B. 60 m
- C. 34 m
- D. 30 m
- E. ?

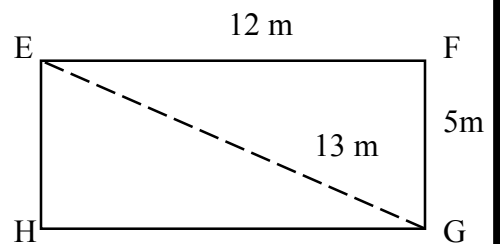

69. Find the area of triangle XYZ.  $A = \frac{1}{2} bh$

- A.  $48 \text{ cm}^2$   
 B.  $59 \text{ cm}^2$   
 C.  $100 \text{ cm}^2$   
 D.  $200 \text{ cm}^2$   
 E. ?

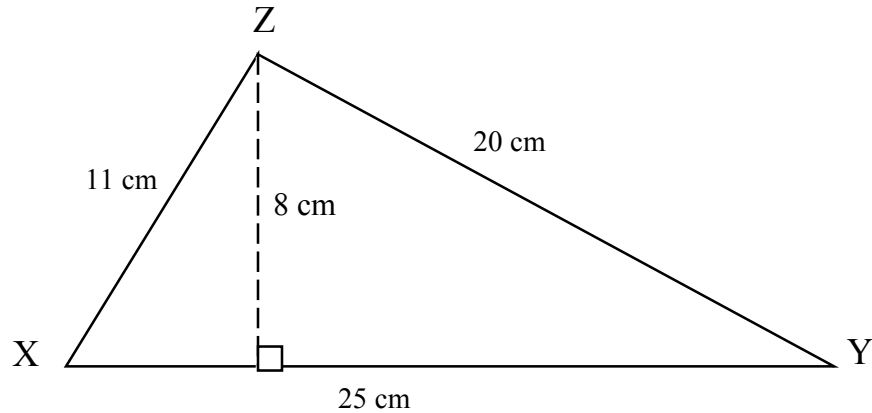

70. Find the area of the parallelogram  $A = bh$

- A.  $14 \text{ cm}^2$   
 B.  $14.5 \text{ cm}^2$   
 C.  $21.5 \text{ cm}^2$   
 D.  $24.5 \text{ cm}^2$   
 E. ?

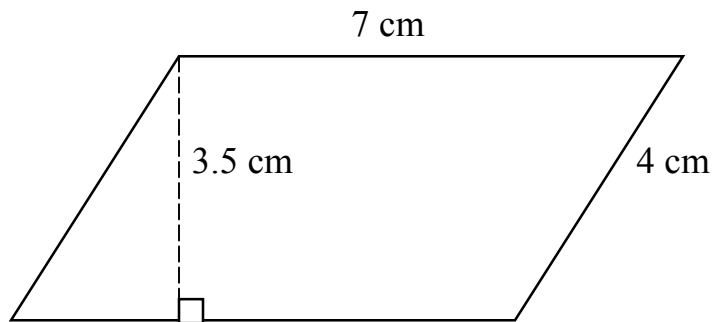

71. Choose the operations needed to solve this problem.

Mr. Curtis made a total of \$1364 in monthly car payments last year.  
 Mr. Nolan pays \$141 per month for his car payment. How much more  
 per month does Mr. Nolan pay?

- A. Add, then divide  
 B. Divide, the subtract  
 C. Multiply, then divide  
 D. Subtract, the multiply  
 E. ?

72. Choose the equation that fits the following problems.

One number is 12 more than another number. The sum of the numbers is 36. Find each number.

- A.  $X + 12 = 36$
- B.  $X + 48 = 36$
- C.  $12 + 36 = X$
- D.  $X + (X + 12) = 36$
- E. ?

73. Solve the following problem.

Hal invested \$720.00 in stock, he then sold it for a 20% profit. What was the selling price of the stock?

- A. \$864.00
- B. \$740.00
- C. \$700.00
- D. \$144.00
- E. ?

74. Solve the following problem.

A pipe 30 feet long is to be cut into eight equal pieces. How long will each piece be?

- A. 4 feet
- B.  $3\frac{3}{4}$  feet
- C. 3.6 feet
- D. 3 feet
- E. ?



75. Use the bar graph below to solve the following problem.

Between which two days did the largest increase in stereo tape sales occur?

- A. Mon. – Tues.
- B. Tues. – Wed.
- C. Wed. – Thurs.
- D. Thurs. – Fri.
- E. ?

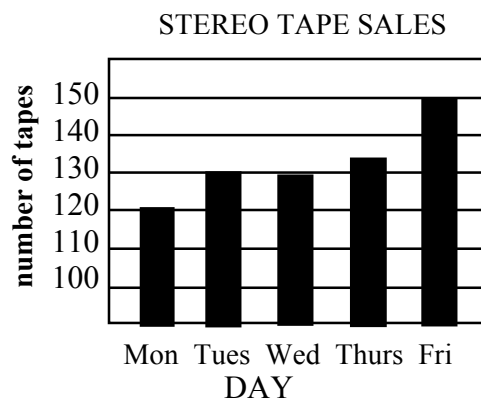

76. Choose the set that shows the numbers ordered from greatest to least.

- A. {0.6, .06, .006}
- B. {.006, .06, 0.6}
- C. {0.6, .006, .06}
- D. {.06, 0.6, .006}
- E. ?

77. Choose the set that shows fractions ordered from least to greatest.

- A.  $\{\frac{1}{2}, \frac{2}{3}, \frac{1}{4}, \frac{3}{8}\}$
- B.  $\{\frac{2}{3}, \frac{1}{2}, \frac{3}{8}, \frac{1}{4}\}$
- C.  $\{\frac{1}{4}, \frac{3}{8}, \frac{1}{2}, \frac{2}{3}\}$
- D.  $\{\frac{1}{2}, \frac{1}{4}, \frac{2}{3}, \frac{3}{8}\}$
- E. ?

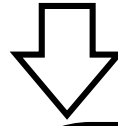
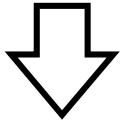

78. Choose the additive inverse of 5.

- A. -5
- B. 25
- C.  $\frac{1}{5}$
- D. 0
- E. ?

81. SOLVE:  $66\frac{2}{3}\%$  of 198.

- A. 132
- B. 66
- C. 13.2
- D. 6.6
- E. ?

79. Find the prime factorization of 324.

- A.  $2 \cdot 3^5$
- B.  $2^2 \cdot 3 \square$
- C.  $2^3 \cdot 3^3$
- D.  $2 \square \cdot 3^2$
- E. ?

82. ADD:

- A.  $-1\frac{1}{2}$  +  $\frac{-5}{6}$
- B.  $-\frac{1}{2}$
- C.  $-\frac{1}{6}$
- D.  $-\frac{1}{9}$
- E. ?

80. SOLVE: 13 is the square root of \_\_\_\_\_.

- A. -13
- B. 26
- C. 169
- D. 1313
- E. ?

83. SUBTRACT:  $6.4 - (-2.74) = \square$

- A. 3.66
- B. 3.74
- C. 4.34
- D. 9.14
- E. ?

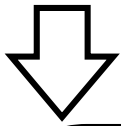

84. MULTIPLY:  $-2\frac{1}{2} \cdot -5\frac{1}{3} =$

- A. 16
- B.  $13\frac{1}{3}$
- C.  $-\frac{15}{32}$
- D.  $-10\frac{1}{6}$
- E. ?

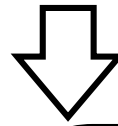

87. Find the length of side C.

$$(a^2 + b^2 = c^2)$$

- A. 10"
- B. 14"
- C. 28"
- D. 100"
- E. ?

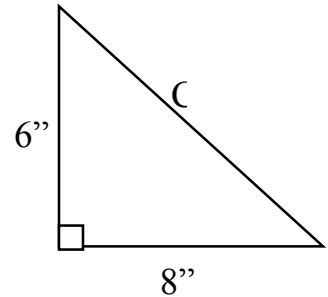

85. DIVIDE:  $.0128 \div .0032 =$

- A. 40
- B. 4
- C. 2.5
- D. .25
- E. ?

88. Find the length of side b.

$$(a^2 + b^2 = c^2)$$

- A. 8 cm
- B. 12 cm
- C. 16 cm
- D. 20 cm
- E. ?

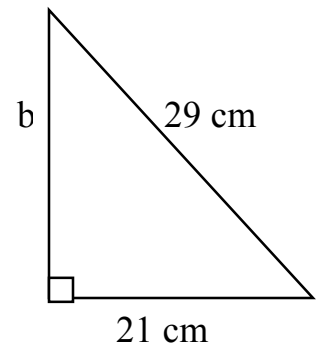

86. Choose the similar triangles.

- A. #1 and #2
- B. #1 and #4
- C. #2 and #3
- D. #3 and #4
- E. ?

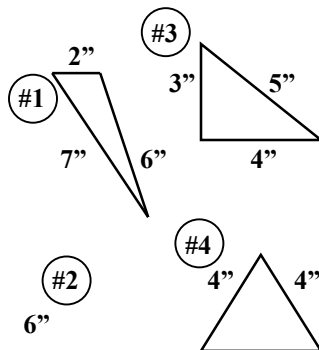

89. The two triangles are similar. Find the measure of side h.

- A. 6"
- B. 9"
- C. 12"
- D. 15"
- E. ?

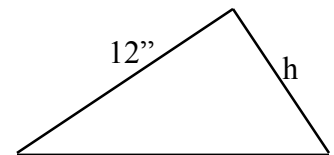

90. Find the distance from Fruita to Delta.

- A. 4.75 km
- B. 25 km
- C. 80 km
- D. 95 km
- E. ?

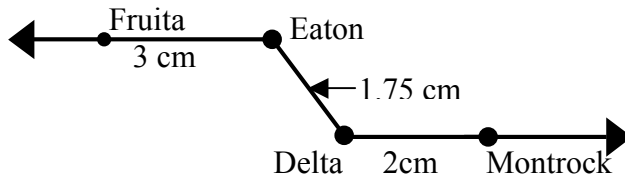

Scale  
1 cm = 20 km

91. SOLVE: 5 square yards = \_\_\_\_\_ square feet.

- A.  $1\frac{2}{3}$
- B. 15
- C. 25
- D. 45
- E. ?

92. Find the area of the polygon.

- A. 81 ft<sup>2</sup>
- B. 51 ft<sup>2</sup>
- C. 42 ft<sup>2</sup>
- D. 39 ft<sup>2</sup>
- E. ?

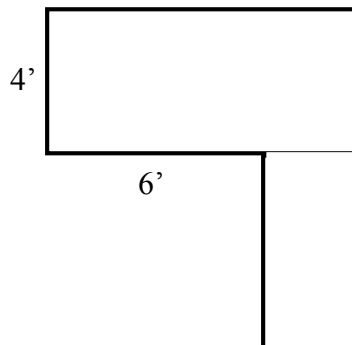

93. Find the volume of the rectangle prism.

$$V = lwh$$

- A.  $19 \text{ m}^3$   
 B.  $70 \text{ m}^3$   
 C.  $88 \text{ m}^3$   
 D.  $165 \text{ m}^3$   
 E. ?

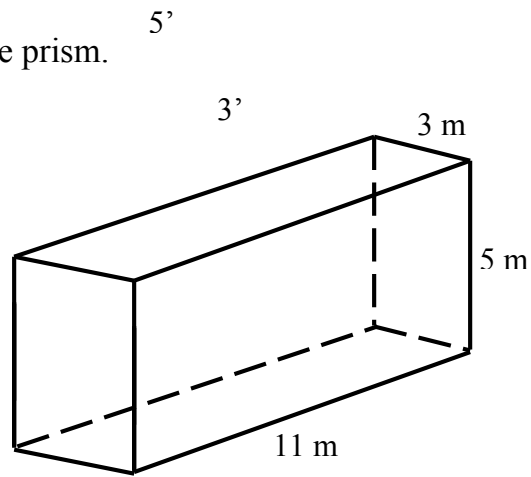

94. Find the area of the circle.

$$\text{Area} = \pi \cdot r^2 \quad \pi = 3.14$$

- A.  $37.68 \text{ in}^2$   
 B.  $56.52 \text{ in}^2$   
 C.  $113.04 \text{ in}^2$   
 D.  $452.16 \text{ in}^2$   
 E. ?

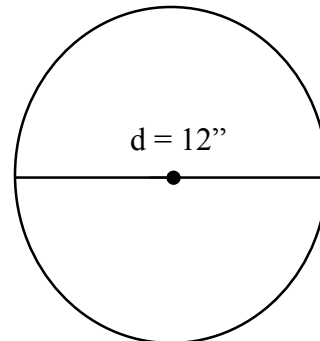

95. Find the circumference of the circle.

$$C = \pi \cdot d \quad \pi = \frac{22}{7}$$

- A. 616 cm  
 B. 88 cm  
 C. 56 cm  
 D. 28 cm  
 E. ?

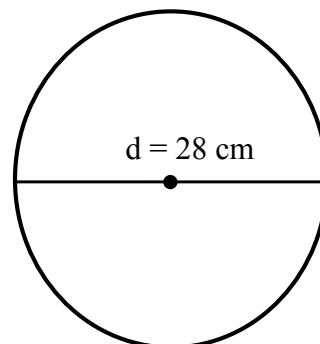

96. Choose the equation that fits the problem.

A gold charm and a gold chain together cost \$15.00. If the charm costs 3 dollars more than the chain, find the cost of the chain.

- A.  $15 - 3 = n$
- B.  $15 + 3 = n$
- C.  $18 + 3 = n$
- D.  $n + (n + 3) = 15$
- E. ?

97. Choose the best estimate for this problem.

The regular price of a stereo is \$329.95. During a sale it is advertised at 30% off. Find the sale price of the stereo.

- A. \$70
- B. \$230
- C. \$260
- D. \$300
- E. ?

98. Solve the following problem.

Mr. Beck left Las Vegas at 7:30 a.m. for Reno, a distance of 720 kilometers. Averaging 72 kilometers per hour, what time did he arrive in Reno?

- A. 5:30 p.m.
- B. 6:30 p.m.
- C. 7:30 p.m.
- D. 5:30 p.m.
- E. ?

99. Mr. Goldbrick's will left  $\frac{1}{3}$  of his estate to his son John:  $\frac{1}{4}$  to his son James:  $\frac{1}{6}$  to his nephew Tom, and the remainder to his daughter Susan. What fractional part of the estate did Susan get?
- A.  $\frac{3}{4}$
- B.  $\frac{1}{3}$
- C.  $\frac{1}{4}$
- D.  $\frac{1}{6}$
- E. ?

100. Use the double bar graph to answer the following problem.

Which auto shows the greatest increase in M.P.G. from 1979 to 1980?

- A. Jupiter
- B. Pluto
- C. Saturn
- D. Thor
- E. ?

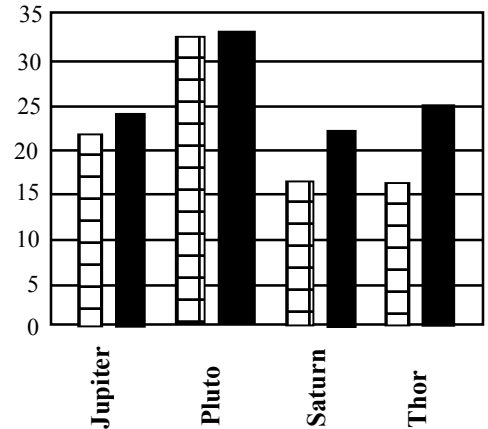
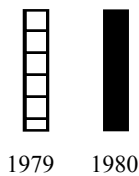

END OF TEST